

### D-Link DWL-1800

Wireless Outdoor Bridge

# 1

## Package Contents

- Indoor unit
- Outdoor unit with integrated antenna
- Pole mounting kit for the Outdoor unit (includes two brackets and four sets of screws, nuts and washers)
- 110/220V AC Power Cord
- 20 meter Indoor to Outdoor cable
- 3 shielded RJ-45 connectors
- CD containing: Manual and Configuration Utility
- Quick Installation Guides

This Quick Installation Guide is intended for experienced installers and network administrators. Please refer to the D-Link AirPremier DWL-1800 Manual on the CD for further details and information regarding the installation procedures.

**The Base Unit Station DWL-1800B is a required product in all installations, whether PtP or PtMP architecture; the remote stations can't communicate to each others without DWL-1800B.**



Outdoor units and antennas should be installed **ONLY** by experienced installers who are familiar with local building and safety codes and, wherever applicable, are licensed by the appropriate authorities. Failure to do so may void the D-Link product warranty and may expose the end user or the service provider to legal and financial liabilities.

D-Link and its resellers or distributors are not liable for injury, damage or violation of regulations associated with the installation of outdoor units or antennas.

## System Description

The products come in two options: the basic DWL-1800B (BU) and DWL-1800R (RB) units come with a high gain flat antenna integrated on the front cover of the Outdoor unit. In this model, the front cover also functions as a protective sun cover.

### The installation process should follow these general steps:

1. Select an appropriate locations for the Outdoor unit, the antenna (if using an external antenna) and the Indoor unit.
2. Connect a ground cable between the Outdoor unit and an appropriate grounding point.
3. Remove the service box assembly of the Outdoor unit, unscrew the top nut and route the indoor-outdoor cable through the top nut and the service box. Assemble an RJ-45 connector on the cable, connect it to the Ethernet connector, replace the service box and tighten the nut. Make sure that the external jack of the cable is well inside the service box to guarantee a good sealing. Route the cable to the location selected for the Indoor unit.

---

### Preparing the Indoor-to-Outdoor Cable

The Indoor-to-Outdoor cable provides pin-to-pin connection on both sides.

It is supplied open-ended, to allow the installer to conveniently route the cable through the service box of the Outdoor unit and through a wall into the building.

The following diagram shows the wire pair connections required for the Indoor-to-Outdoor cable.

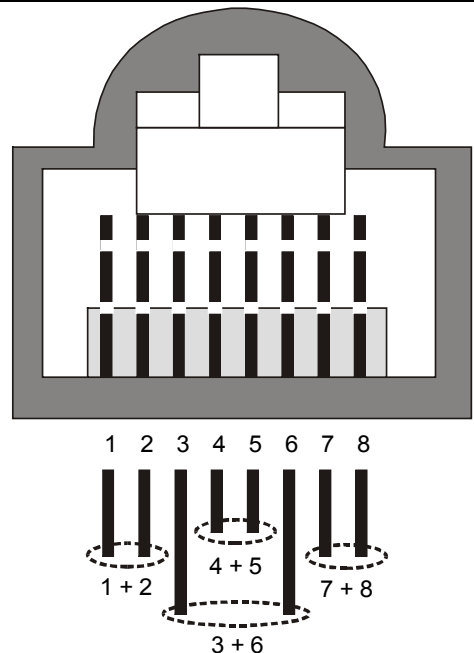

- 
4. Mount the Indoor unit. Assemble an RJ-45 connector with a protective cover on the indoor side of the Indoor-to-Outdoor cable and connect it to the Indoor unit's **Radio** port. Prepare the power cable (if supplied open ended) and use it to connect the Indoor unit to the AC mains.

---

**Note:** *The Indoor unit should be connected to the power source only after it has been connected to the Outdoor unit.*

---

---

**Note:** *If the power cord supplied with the unit is open ended, connect to it a power plug appropriate to the country in which the unit is being installed. The color codes of the cable are:*

<i>brown</i>	<i>phase ~</i>
<i>blue</i>	<i>neutral 0</i>
<i>yellow/green</i>	<i>grounding ≡</i>

*The operating AC mains voltage of the Indoor unit is marked on the rear panel of the unit*

---

5. Connect the Indoor unit **Ethernet** port to the Ethernet hub using a **straight** Ethernet cable or directly to the PC's NIC using **crossed** cable.
6. Align the antenna and verify connectivity with the other unit(s).

### To perform antenna alignment:

1. Power on both units.
2. Synchronize the units by aligning the antennas at the main and remote sites until maximum signal quality is obtained. Check the signal strength RSSI bar on the bottom panel of the DWL-1800R (RB) bottom panel. If the received signal quality is lower than expected for this antenna/range combination, change antenna height and verify RF cables connections.

### Verifying Correct Operation

To verify proper operation of the Outdoor unit, view the LED indicators located on the bottom panel of the unit as shown in the following table:

**Outdoor Unit LEDs**

<b>Name</b>	<b>Description</b>	<b>Functionality</b>
WLAN	Wireless Link Indicator	<i>Blinking Green</i> – Data received or transmitted on wireless link. Blinking rate is lower when there is no wireless traffic.
DC Power	Self Test and Power indication	<i>Green</i> – Self test passed and 48VDC power is received by the outdoor unit <i>Red</i> – Self test failed. Firmware did not loaded successfully.
ETH	Ethernet activity / Connectivity indication	<i>OFF</i> –Ethernet connectivity is OK. No traffic activity detected on the port. <i>Blinking Green</i> –Ethernet connectivity is OK, with traffic on the port. <i>Red</i> – No Ethernet connectivity.
RSSI BAR		<i>DWL-1800R (RB)</i> : Received Signal Strength Indication <i>DWL-1800B (BU)</i> : Number of associated RB units

To verify proper operation of the Indoor unit, view the LED indicators located on the front panel of the unit as shown in the following table:

### Indoor Unit LEDs

Name	Description	Functionality
POWER	Power indication	<i>Green</i> -The Indoor unit supplies 48VDC to the Radio port <i>Off</i> - No power is supplied to the Radio port.
LINK	Self Test and Remote Ethernet Link indication	<i>Off</i> – No Ethernet connectivity has been detected between the outdoor unit and the device connected to the indoor unit. <i>Orange</i> – Self-test passed and Ethernet connection between the outdoor unit and the device connected to the indoor units is detected. <b>Note: The LINK LED indicates end-to-end connection between the outdoor unit and the Ethernet connection to the indoor unit.</b>

### Quick Start to Wireless Networking

Perform the following steps to configure a WLAN for the first time:

1. Physically connect the DWL-1800B/DWL-1800R units to the Ethernet LAN. Make sure they are switched on. The D-Link AirPremier DWL-1800 wireless network will be up and running immediately. If you are content with the default settings of the DWL-1800B/DWL-1800R units, you can stop right here. It is more likely however, that you want to assign different radio frequencies to each DWL-1800B/DWL-1800R, or impose some restrictions on the use of your wireless network.
2. To be able to manage the DWL-1800B/DWL-1800R units via SNMP, each DWL-1800B/DWL-1800R needs a unique IP address. If you provide a DHCP or BOOTP service on your LAN (and have sufficient free IP addresses available) this will be taken care of automatically. If not, refer to User's Guide for further information on assigning IP addresses.
3. Use the D-Link AirPremier DWL-1800 Configuration utility to configure the network settings according to your needs.
4. Select the radio channels of the DWL-1800B/DWL-1800R units according to your cell plan. See the User's Guide for further details and information regarding cell planning and channel selection.

## 2

### Preparing The Indoor To Outdoor Cable

The Indoor-to-Outdoor cable provides pin-to-pin connection on both sides. It is supplied open-ended at both sides, to allow the installer to conveniently route the cable into the waterproof seal off the Outdoor unit and through holes in walls.

The figure below shows the wire pair connections required for the Indoor-to-Outdoor cable.

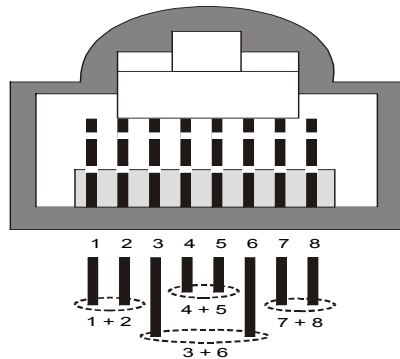

Use a standard crimp tool for RJ45 connectors to prepare the wires, insert them into the appropriate pins and use the crimp tool to crimp the connector. Make sure to do the following:

- Remove as smaller length as possible of the external jacket to verify that the external jacket will be well inside the service box when connected to the Outdoor unit to ensure good sealing.
- Take back the shield drain wire before inserting the cable into the RJ-45 connector, to ensure a good connection with the connector's shield after crimping.

## 3

### Connecting the Indoor-to-Outdoor Cable

- Remove the two screws holding the waterproof seal assembly to the Outdoor unit and remove the waterproof seal.
- Unscrew the top nut from the waterproof seal.

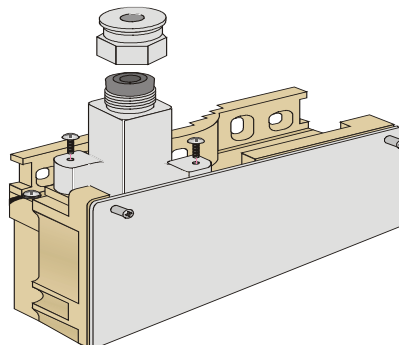

**Routing the Indoor-to-Outdoor Cable through the Waterproof Seal**

3. Route an uncrimped straight Ethernet cable (8-wire, 24 AWG pin-to-pin) through the top nut and the waterproof seal.  
Note: The 8-wire cable should be shielded.
4. Insert and crimp an RJ45 connector.
5. Connect the cable to the outdoor unit RJ45 connector.
6. Replace the waterproof seal assembly to the Outdoor unit and then replace the top nut. Make sure that the external jack of the cable is well inside the service box to guarantee a good sealing.
7. Route the cable to the location selected for the Indoor unit.
8. Assemble an RJ-45 connector with a protective cover on the indoor side of the Indoor-to-Outdoor cable and connect it to the Indoor unit's Radio port.

# 4

## System Troubleshooting

The following troubleshooting guide provides answers to some of the more common problems that may occur when installing and using the D-Link Air Premier DWL-1800. If problems not mentioned in this guide should arise, checking the Ethernet and WLAN counters may help. If the problem persists, please feel free to contact your local distributor or the D-Link Technical Support Department.

### Troubleshooting Guide

Problem and Indication	Possible Cause	Corrective Action
No power to unit. Power LED is off.	Power cord is not properly connected.	Verify power cord is properly connected to the DWL-1800 unit and to the power outlet.
Failure to establish wireless link. WIRELESS LINK LED is off and unit resets every few minutes.	<ol style="list-style-type: none"> <li>1. Power supply to units may be faulty</li> <li>2. The DWL-1800R units may not have the same ESSID as the DWL-1800B.</li> </ol>	<ol style="list-style-type: none"> <li>1. Verify power to units.</li> <li>2. Verify that all units in the network have the same ESSID (ESSID must be identical in all units in the WLAN; the ESSID is case sensitive). Check that the units are on the same channel.</li> <li>3. Verify wireless link               <ul style="list-style-type: none"> <li>• Set DWL-1800B and DWL-1800R units side by side.</li> <li>• Power on each unit and see if a wireless link is established</li> <li>• If the units fail to associate, reset units to factory default values. The units should now establish a wireless link.</li> </ul> </li> </ol>

<b>Problem and Indication</b>	<b>Possible Cause</b>	<b>Corrective Action</b>
<p>Failure to establish wireless link (“D” models/external antennas)</p>	<ol style="list-style-type: none"> <li>1. Power supply to units may be faulty.</li> <li>2. Cables may be improperly connected</li> <li>3. There may be some problem with antenna installation.</li> </ol>	<ol style="list-style-type: none"> <li>1. Verify power to units.</li> <li>2. Verify that all cables are connected securely.</li> <li>3. Refer to previous Section and verify wireless link between the units.</li> <li>4. Verify that the antenna(s) are properly installed (see relevant section in this manual): <ul style="list-style-type: none"> <li>• Check antenna alignment.</li> <li>• Verify that antenna polarization is the same at both ends.</li> <li>• Verify that the range matches specifications.</li> <li>• Verify line-of-sight/antenna alignment/antenna height.</li> </ul> </li> </ol>
<p>Wireless link established, but there is no Ethernet activity (DWL-1800B and DWL-1800R units).</p>	<ol style="list-style-type: none"> <li>1. Ethernet hub port or UTP cable is faulty.</li> <li>2. Ethernet port in unit is faulty. <ol style="list-style-type: none"> <li>1. The DWL-1800R is associated to a DWL-1800B unit that is not connected correctly to the LAN.</li> </ol> </li> </ol>	<ol style="list-style-type: none"> <li>1. Check that the LINK LED is lighted Green. If this is not the case, the port is inactive. Try another port on the hub or another UTP cable.</li> <li>2. Verify that Ethernet port in unit is working. Ping unit to verify Ethernet connection.</li> <li>3. Verify that you are using a cross-over UTP cable (pins 1 &amp; 3, 2 &amp; 6) if connected directly to a workstation, or a straight-through cable if connected to a hub.</li> <li>4. Check the unit’s LINK LED indicator and check the Ethernet counters in the monitor to verify Ethernet activity (see manual section 3.3.4).</li> <li>5. Check that the DWL-1800B is correctly connected to the LAN.</li> </ol>



## DWL-1800 FAQ

### **General**

#### ***Can the DWL-1800R indoor unit be placed outdoors?***

It is not recommended. The DWL-1800 indoor units are specified to operate between 0°C and 40°C and is not weather proof so it is best to mount the DWL-1800R indoors or in a protective cabinet.

#### ***Do DWL-1800 units support 802.1Q VLAN?***

Yes, but the support is limited to transparent operation. This means that the DWL-1800 does not take any action on 802.1Q frames, but will transparently pass them within a VLAN network.

#### ***What is the maximum number of networked PCs the DWL-1800B/ DWL-1800R can learn?***

1024 network MAC addresses can be learned by the DWL-1800B/DWL-1800R from the LAN side.

#### ***Can the DWL-1800B/DWL-1800R be used for multi-point as well as point-to-point links?***

Yes. The DWL-1800B can support multiple DWL-1800R units creating a point-to-multi-point network.

#### ***How many DWL-1800R units can one DWL-1800B support?***

The maximum number of associations is 128.

#### ***What is the practical limit to the number of DWL-1800R units per DWL-1800B? And, what performance can I expect for a multi-point link?***

This depends upon average throughput expectations. All clients would have the maximum throughput available for burst traffic, however the overall average would depend on the utilization of the network. For example, in a heavily utilized network needing about 350Kbps to 500kbps average net throughput per site, 9 to 12 DWL-1800R's would be the limit. For a moderately utilized network needing about 175Kbps to 258Kbps average, 18 to 24 DWL-1800R's should be used, and for a lightly used network needing 32Kbps to 48Kbps average net throughput per site could use up to 128 DWL-1800R's.

#### ***What is the range of the DWL-1800B/ DWL-1800R Bridges?***

15 miles/24Km (FCC) or 10 KM (ETSI) can be achieved using the UNI-24 antenna kit for a point-to-point link. Consult the antenna and accessory guide range tables for distances using other antennas.

Does the DWL-1800B supports 802.1d spanning tree protocol?

No, the DWL-1800B/DWL-1800R does not support spanning tree.



***What is the normal PER (Packet Error Rate) for the DWL-1800B/DWL-1800R?***

The error rate will be about 4%-6% (transmitted fragments vs. retry count). This is typical when operating in a non-interference environment at maximum range for bi-directional traffic loads. If the traffic load is more uni-directional, then the PER will be less.

***What is the best value for the CW min parameter on the DWL-1800?***

Setting the CW min parameter to 31 for heavy bi-directional traffic loads will minimize the PER. Setting the CW min to 15 will improve performance for more uni-directional traffic loads. CW min 7 should only be used for short-range point-to-point links, and 63 should be used for large, long-range multi-point links.

***Is the D-Link AirPremier DWL-1800 compatible with other D-Link wireless equipment from other vendors?***

Yes. However, for the outdoor bridges, interoperability can vary from vendor to vendor and in some cases it may not operate if the manufacturer's implementation is not pure 802.11b. The DWL-1800B/DWL-1800R can operate at 1, 2Mbps 5.5Mbps and 11Mbps with D-Link Air and Air Plus wireless family products. D-Link Air Premier DWL-1800 units are fully WI-FI compliant.

***How many DWL-1800B or DWL-1800R units can be collocated on the same building or tower?***

You can collocate up to 3 DWL-1800B or DWL-1800R units on the same structure. Each unit is assigned to one of the non-overlapping channels, 1, 6, or 11.

***Can a Frequency Hopping network operate in the same area as the D-Link Air Premier DWL-1800?***

Yes, but in a collocated network both products will suffer some a decrease in performance. The degree of performance loss depends on network utilization. For example, the higher the utilization of the Frequency Hopping network, the higher the level of impact on the Direct Sequence (DWL-1800) network, and vice versa. Typically, in light to moderately utilized networks, the performance loss is not significant.

***Can I use D-Link Air Premier DWL-1800 Bridges to feed a Frequency Hopping distribution point?***

Yes, bandwidth sharing between the Direct Sequence and Frequency Hopping products can be minimized if the network is designed using cross-polarized directional antennas with as much spatial separation as possible. Contact technical support for more information.

**Performance**

***What is the throughput of the D-Link Air Premier DWL-1800?***

The DWL-1800B/DWL-1800R bridge link typical performance is 4.2Mbps using TCP and 6.2Mbps using UDP. For long-range links, the performance drops by about 5%.

***What if the D-Link Air Premier DWL-1800 link experiences interference?***

If interference is affecting the DWL-1800 link, one of the other channels may be selected to operate away from the frequency of the interference. Also, physically re-locating the antennas may help.

***What is the typical latency of a DWL-1800B/DWL-1800R?***

A point-to-point link would realize about 3mS latency.

## **Firmware**

### ***Can the DWL-1800B/ DWL-1800R firmware be upgraded?***

Yes, the firmware in the DWL-1800B/DWL-1800R is stored in flash and is upgraded using the built in Configuration Utility or the TFTP server.

### ***Can the DWL-1800B/DWL-1800R flash be erased or the firmware changed by an unauthorized person?***

No, the TFTP server in the DWL-1800B/DWL-1800R requires the SNMP write community name (password) to perform an upgrade.

### ***Can the firmware flash be corrupted when upgrading to a new version?***

Yes, if the TFTP file transfer is interrupted during a flash update the firmware may be corrupted. The D-Link Air Premier DWL-1800 has a backup flash, which contains the previous version for firmware. If the primary flash is corrupt, then the backup is automatically used to return the unit to an operating state.

### ***When does the back up flash image get upgraded?***

After completing a firmware upgrade, the backup flash containing the old firmware version is overwritten with the new version on the new power on cycle.

### ***Can D-Link Air Premier DWL-1800 firmware be downgraded?***

Yes, an earlier version of firmware can overwrite a newer version.

### ***Can the previous version of firmware be kept?***

The previous version of firmware cannot be kept on the DWL-1800 itself, but can be stored on your PC and loaded if needed.

## **Configuration**

### ***Can the regulatory domain (country) of a DWL-1800 unit be changed?***

No. The regulatory domain is factory set.

### ***How can the DWL-1800 be configured or managed if the SNMP Community name has been forgotten?***

Press the reset button on the top panel with a paper clip. This will set the read and write Community names to public and private, respectively.

### ***How can the DWL-1800 unit be returned to factory default settings?***

There are two ways. One way is to use the Default button on the Station Control Tab in the DWL-1800 Configuration Utility. The other is to press and hold the reset button on the back of the unit while powering on the unit. Remember that all settings including IP addresses will be lost when setting defaults.

## **Management**

*What management options are available for the DWL-1800?*

The DWL-1800B/DWL-1800R comes with a graphical Configuration Utility that operates on any Windows based network ready PC. With this utility you can configure and monitor every DWL-1800 on your network. You can also use the DWL-1800 SNMP MIB on standard management platforms like SNMPc, and HP Openview.

*Does the DWL-1800 offer out-of-band management?*

No, the DWL-1800 does not offer out-of-band management, such as a serial port. The DWL-1800 is managed in-band only via the DWL-1800 Configuration Utility or SNMP.

*What installation and site survey tools are available for DWL-1800/DWL-1800?*

The DWL-1800 comes with a Windows based manager utility. With this utility you can configure link parameters and monitor signal quality and RSSI (received signal strength indication). Optimizing antenna alignment is done using the signal quality and RSSI display. Any computer on the network can use this utility to manage the DWL-1800B/DWL-1800R.



## **Technical Support**

The most recent software and user documentation is on the **D-Link** website.

D-Link provides free technical support for customers during the warranty period on this product.

Customers can contact **D-Link Technical Support** through the web site.

**[www.dlink.com.tw](http://www.dlink.com.tw)**

Please also *refer to the list of **D-Link** locations that is in the next page.*

### **CE Mark Warning**

This is a Class B product. In a domestic environment, this product may cause radio interference, in which case the user may be required to take adequate measures

### **Warnung!**

Dies ist in Produkt der Klasse B. Im Wohnbereich kann dieses Produkt Funkstoerungen verursachen. In diesem Fall kann vom Benutzer verlangt werden, angemessene Massnahmen zu ergreifen.

### **Advertencia de Marca de la CE**

Este es un producto de Clase B. En un entorno doméstico, puede causar interferencias de radio, en cuyo case, puede requerirse al usuario para que adopte las medidas adecuadas.

### **Attention!**

Ceci est un produit de classe B. Dans un environnement domestique, ce produit pourrait causer des interférences radio, auquel cas l'utilisateur devrait prendre les mesures adéquates.

### **Attenzione!**

Il presente prodotto appartiene alla classe B. Se utilizzato in ambiente domestico il prodotto può causare interferenze radio, nel cui caso è possibile che l'utente debba assumere provvedimenti adeguati.

### **FCC Warning**

This equipment has been tested and found to comply with the limits for a Class B digital device, pursuant to part 15 of the FCC Rules. These limits are designed to provide reasonable protection against harmful interference in a residential installation. This equipment generates, uses and can radiate radio frequency energy and, if not installed and used in accordance with the instructions, may cause harmful interference to radio communications. However, there is no guarantee that interference will not occur in a particular installation. If this equipment does cause harmful interference to radio or television reception, which can be determined by turning the equipment off and on, the user is encouraged to try to correct the interference by one or more of the following measures:

- Reorient or relocate the receiving antenna.
- Increase the separation between the equipment and receiver.
- Connect the equipment into an outlet on a circuit different from that to which the receiver is connected.
- Consult the dealer or an experienced radio/ TV technician for help.

## **AVERTISSEMENT AUX UTILISATEURS**

La décision N° 01-480 en date du 23 mai 2001 prise par l'Autorité de Régulation des Télécommunications (ART) autorise l'utilisation d'une partie de la bande de fréquences 2400-2483,5 MHz pour les réseaux locaux radioélectriques (RLAN)

Au niveau national, seule la bande 2446,5-2483,5 MHz est autorisée pour des produits ayant une puissance limitée à 100 mW

Cette bande de fréquences correspond aux canaux 10,11,12 et 13.

En installant et utilisant les produits réseaux sans fils de la gamme proposée par D-Link, vous vous engagez donc à respecter cette réglementation et à n'utiliser que ces 4 canaux.

## **WARNING**

The Decision N° 01-480 taken by ART (Autorité de Régulation de Télécommunications) on May 23, 2001 authorizes the utilisation of a part of the 2400-2483.5MHz band for Radio Local Area Network (RLAN) in France.

Only the 2446.5-2483.5MHz band is authorized for RLAN with products with a limited power to 100mW.

This band concerns the channels 10, 11, 12 and 13.

Using and installing D-Link Wireless solutions for RLAN, you commit to respect this regulation et to use only these four channels.



# Declaration of Conformity

Hereby, D-Link Corporation, declares that this DWL-1800B, DWL-1800R is in compliance with the essential requirements and other relevant provisions of Directive 1999/5/EC.

The following importer/manufacturer is responsible for this declaration:

Company Name : D-Link Corporation  
Company Address : No.8, Li-shing Road VII, Science-based Industrial Park, Hsinchu, Taiwan, R.O.C.  
Telephone : +886-3-563-6666 Facsimile: +886-3-578-1861

Person is responsible for marking this declaration:

Sam Liang  
Name (Full Name)

President  
Position/ Title

August 7, 2002  
Date

  
Legal Signature

# D-Link® Offices

<b>AUSTRALIA</b>	<b>D-LINK AUSTRALIA</b> Unit 16, 390 Eastern Valley Way, Roseville, NSW 2069, Australia TEL: 61-2-9417-7100 FAX: 61-2-9417-1077 TOLL FREE: 1800-177-100 (Australia), 0800-900900 (New Zealand) E-MAIL: support@dlink.com.au, <a href="mailto:info@dlink.com.au">info@dlink.com.au</a> URL: <a href="http://www.dlink.com.au">www.dlink.com.au</a>
<b>BENELUX</b>	<b>D-LINK BENELUX</b> Fellenoord 130, 5611 ZB Eindhoven, The Netherlands TEL: 31-40-2668713 FAX: 31-40-2668666 E-MAIL: <a href="mailto:info@dlink-benelux.nl">info@dlink-benelux.nl</a> , <a href="mailto:info@dlink-benelux.be">info@dlink-benelux.be</a> URL: <a href="http://www.dlink-benelux.nl/">www.dlink-benelux.nl/</a> , <a href="http://www.dlink-benelux.be/">www.dlink-benelux.be/</a>
<b>CANADA</b>	<b>D-LINK CANADA</b> #2180 Winston Park Drive, Oakville, Ontario, L6H 5W1 Canada TEL: 1-905-829-5033 FAX: 1-905-829-5095 FREE CALL: 1-800-354-6522 E-MAIL: techsup@dlink.ca URL: <a href="http://www.dlink.ca">www.dlink.ca</a> FTP: <a href="ftp://ftp.dlinknet.com">ftp.dlinknet.com</a>
<b>CHILE</b>	<b>D-LINK SOUTH AMERICA</b> Isidora Goyechea 2934 of 702, Las Condes, Santiago - Chile S.A. TEL: 56-2-232-3185 FAX: 56-2-232-0923 E-MAIL: ccasassu@dlink.cl, tsilva@dlink.cl URL: <a href="http://www.dlink.cl">www.dlink.cl</a>
<b>CHINA</b>	<b>D-LINK CHINA</b> 2F, Sigma Building, 49 Zhichun Road, Haidian District, 100080 Beijing, China TEL: 86-10-85182533 FAX: 86-10-85182250
<b>DENMARK</b>	<b>D-LINK DENMARK</b> Naverland 2, DK-2600 Glostrup, Copenhagen, Denmark TEL: 45-43-969040 FAX: 45-43-424347 E-MAIL: <a href="mailto:info@dlink.dk">info@dlink.dk</a> URL: <a href="http://www.dlink.dk">www.dlink.dk</a>
<b>EGYPT</b>	<b>D-LINK MIDDLE EAST</b> 7 Assem Ebn Sabet Street, Heliopolis Cairo, Egypt TEL: 202-2456176 FAX: 202-2456192 E-MAIL: <a href="mailto:support@dlink-me.com">support@dlink-me.com</a> URL: <a href="http://www.dlink-me.com">www.dlink-me.com</a>
<b>FINLAND</b>	<b>D-Link FINLAND</b> Thlli-ja Pakkahuone Katajanokanlaituri 5, FIN-00160 Helsinki, Finland TEL: 358-9-622-91660 FAX: 358-9-622-91661 E-MAIL: <a href="mailto:info@dlink-fi.com">info@dlink-fi.com</a> URL: <a href="http://www.dlink-fi.com">www.dlink-fi.com</a>
<b>FRANCE</b>	<b>D-LINK FRANCE</b> Le Florilege #2, Allee de la Fresnerie, 78330 Fontenay le Fleury France TEL: 33-1-302-38688 FAX: 33-1-3023-8689 E-MAIL: <a href="mailto:info@dlink-france.fr">info@dlink-france.fr</a> URL: <a href="http://www.dlink-france.fr">www.dlink-france.fr</a>
<b>GERMANY</b>	<b>D-LINK Central Europe/D-Link Deutschland GmbH</b> Schwalbacher Strasse 74, D-65760 Eschborn, Germany TEL: 49-6196-77990 FAX: 49-6196-7799300 INFO LINE: 00800-7250-0000 (toll free) HELP LINE: 00800-7250-4000 (toll free) REPAIR LINE: 00800-7250-8000 E-MAIL: <a href="mailto:info@dlink.de">info@dlink.de</a> URL: <a href="http://www.dlink.de">www.dlink.de</a>
<b>IBERIA</b>	<b>D-LINK IBERIA</b> Gran Via de Carlos III, 84, 3º Edificio Trade, 08028 BARCELONA TEL: 34 93 4090770 FAX 34 93 4910795 E-MAIL: <a href="mailto:info@dlinkiberia.es">info@dlinkiberia.es</a> URL: <a href="http://www.dlinkiberia.es">www.dlinkiberia.es</a>
<b>INDIA</b>	<b>D-LINK INDIA</b> Plot No.5, Kurla-Bandra Complex Road, Off Cst Road, Santacruz (E), Bombay - 400 098 India TEL: 91-22-652-6696 FAX: 91-22-652-8914 E-MAIL: <a href="mailto:service@dlink.india.com">service@dlink.india.com</a> URL: <a href="http://www.dlink-india.com">www.dlink-india.com</a>
<b>ITALY</b>	<b>D-LINK ITALIA</b> Via Nino Bonnet No. 6/b, 20154 Milano, Italy TEL: 39-02-2900-0676 FAX: 39-02-2900-1723 E-MAIL: <a href="mailto:info@dlink.it">info@dlink.it</a> URL: <a href="http://www.dlink.it">www.dlink.it</a>
<b>JAPAN</b>	<b>D-LINK JAPAN</b> 10F, 8-8-15 Nishi-Gotanda, Shinagawa-ku, Tokyo 141, Japan TEL: 81-3-5434-9678 FAX: 81-3-5434-9868 E-MAIL: <a href="mailto:kida@d-link.co.jp">kida@d-link.co.jp</a> URL: <a href="http://www.d-link.co.jp">www.d-link.co.jp</a>
<b>NORWAY</b>	<b>D-LINK NORWAY</b> Waldemar Thranesgt. 77, 0175 Oslo, Norway TEL: 47-22-991890 FAX: 47-22-207039
<b>RUSSIA</b>	<b>D-LINK RUSSIA</b> Michurinski Prospekt 49, 117607 Moscow, Russia TEL: 7-095-737-3389, 7-095-737-3492 FAX: 7-095-737-3390 E-MAIL: <a href="mailto:vl@dlink.ru">vl@dlink.ru</a> URL: <a href="http://www.dlink.ru">www.dlink.ru</a>
<b>SINGAPORE</b>	<b>D-LINK INTERNATIONAL</b> 1 International Business Park, #03-12 The Synergy, Singapore 609917 TEL: 65-774-6233 FAX: 65-774-6322 E-MAIL: <a href="mailto:info@dlink.com.sg">info@dlink.com.sg</a> URL: <a href="http://www.dlink-intl.com">www.dlink-intl.com</a>
<b>S. AFRICA</b>	<b>D-LINK SOUTH AFRICA</b> 102-106 Witchhazel Avenue, Einetein Park 2, Block B, Highveld Technopark Centurion, South Africa TEL: 27(0)126652165 FAX: 27(0)126652186 E-MAIL: <a href="mailto:attie@d-link.co.za">attie@d-link.co.za</a> URL: <a href="http://www.d-link.co.za">www.d-link.co.za</a>
<b>SWEDEN</b>	<b>D-LINK SWEDEN</b> P.O. Box 15036, S-167 15 Bromma Sweden TEL: 46-(0)8564-61900 FAX: 46-(0)8564-61901 E-MAIL: <a href="mailto:info@dlink.se">info@dlink.se</a> URL: <a href="http://www.dlink.se">www.dlink.se</a>
<b>TAIWAN</b>	<b>D-LINK TAIWAN</b> 2F, No. 119 Pao-Chung Road, Hsin-Tien, Taipei, Taiwan, TEL: 886-2-2910-2626 FAX: 886-2-2910-1515 E-MAIL: <a href="mailto:dssqa@tsc.dlinktw.com.tw">dssqa@tsc.dlinktw.com.tw</a> URL: <a href="http://www.dlinktw.com.tw">www.dlinktw.com.tw</a>
<b>U.K.</b>	<b>D-LINK EUROPE</b> 4th Floor, Merit House, Edgware Road, Colindale, London, NW9 5AB, U.K. TEL: 44-20-8731-5555 FAX: 44-20-8731-5511 E-MAIL: <a href="mailto:info@dlink.co.uk">info@dlink.co.uk</a> URL: <a href="http://www.dlink.co.uk">www.dlink.co.uk</a>
<b>U.S.A.</b>	<b>D-LINK U.S.A.</b> 53 Discovery Drive, Irvine, CA 92618 USA TEL: 1-949-788-0805 FAX: 1-949-753-7033 INFO LINE: 1-877-453-5465 BBS: 1-949-455-1779, 1-949-455-9616 E-MAIL: <a href="mailto:tech@dlink.com">tech@dlink.com</a> , <a href="mailto:support@dlink.com">support@dlink.com</a> URL: <a href="http://www.dlink.com">www.dlink.com</a>